

ALURAD®

Perfect Radiator

DIRECTIONS FOR MOUNTING AND USE

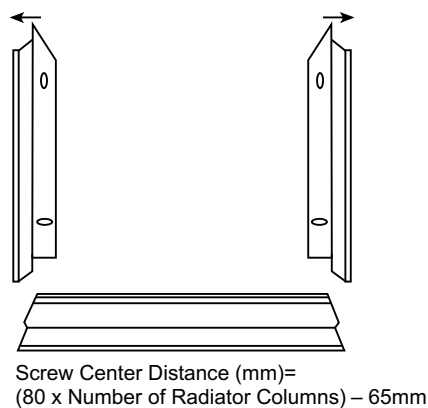
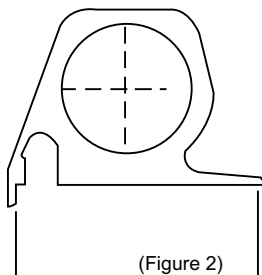
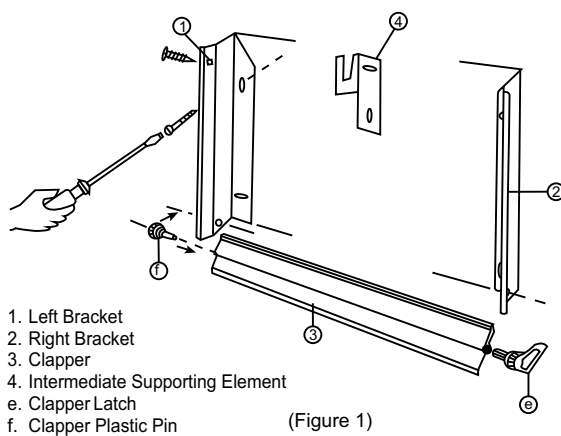

1 The installation connections of Alurad Klas Radiators which are made of aluminum are made in the same way as for other hot-water radiators. Different from other radiators, however, Alurad allows the making of " lower opposite end " connection. Mount the radiator without removing it from its nylon packing. Remove the protective nylon cover by cutting it before use, after completion of all alteration and painting works. The initial putting of the radiator into operation may be carried out while the nylon cover is on.

Alurad Klas Radiators can be easily mounted on the wall using the brackets (Figure 1). The radiator valve connection is 1/2. Either chromium or nickel plated radiator valves should be used. All elements required for mounting are included in the packing. The top side of the radiator is the side with the profile shown in Figure 2.

Mounting Operation

2 If the installation branches are installed, check the position of connection of the radiator. In doing this, pay attention to the measurements given (Figure 3 and Figure 3 a). Place the plastic plugs into their places before making the coupling connections, and then make the required connections according to the style of branching.

3 Mount the left bracket (Figure 1, No 1) onto the wall using the holes bored with a drill, and a screwdriver. (Take care that the bracket is positioned vertically.). After passing the plastic pin of lower clapper (Figure 1, No f) trough the circular hole provided at the bottom of the bracket, fit the joining pin.

4 By taking into consideration the measurements given in Figure 3 and Figure 3 a, determine the location of right bracket. Fit the clapper latch onto the right clapper by passing it through the circular hole provided at the bottom, and then fit its joining pin (Figure 1, No. e). The length of the clapper will also allow you to check whether or not the location of bracket holes and your measurements for mounting the right bracket are correct.

5 After mounting the right bracket loosely in its place too, move the clapper by means of the clapper latch (Figure 4) When you are sure that it moves freely, fix the right bracket securely by tightening its screws firmly.

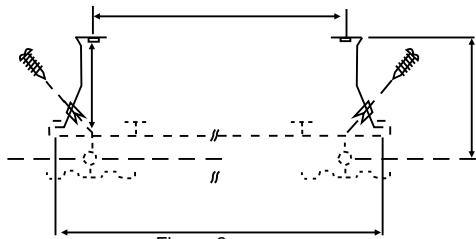

Figure 3 a
Distance between the bracket slide ends (mm) =
(80x Number of Radiator Columns) – 5mm

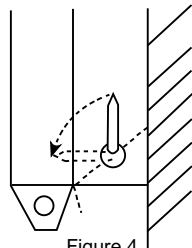

Figure 4
Keeping the clapper closed while the system is in operation will ensure maximum heat efficiency.

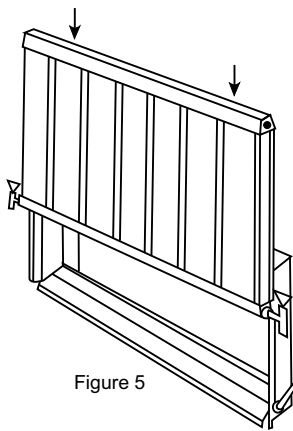

Figure 5

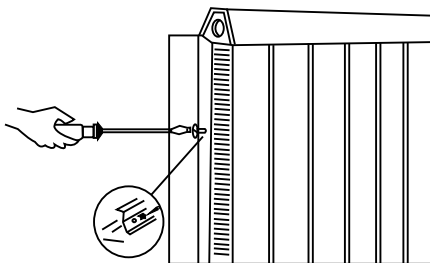

Figure 6

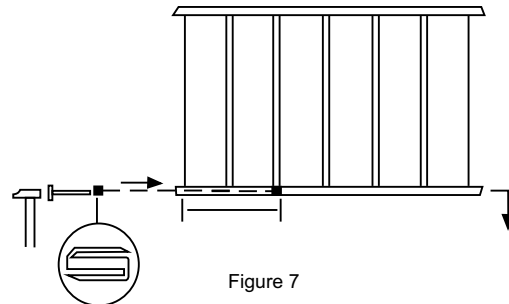

Figure 7

6 Cause the radiator slide down the bracket slides from top of the brackets (Figure 5). If the place of mounting does not permit sliding down from the top due to the presence of parapet, first fix the radiator to one of the brackets from its side (Figure 3 a), and then fit it into its place by pushing in the other bracket.

7 Fit the screws into the plastic inserts provided on the side brackets, and tighten them (Figure 6). **Note:** Where the length of radiator exceeds 140 cm or the number of columns exceeds 18, support the radiator with one supporting bracket, and where the length exceeds 240 cm or the number of columns exceeds 30, support it with two supporting brackets (Figure 1, No 4). Place said supporting brackets to the lower edge of upper water channel as to face the slides and to the middle section of the radiator.

8 Lower Opposite End Connection

Alurad Radiators allow the making of lower opposite end connection without causing any reduction in yield. To meet this purpose, the "direction plug and pusher" shown in Figure 7 will be put into the packing, if a request is made for them in the purchase order.

9 Placement of Direction Plug

In making the lower opposite end connection, the direction plug shall be placed at the following locations as counted from the hot water inlet, using the pusher supplied:

- a) For radiators with up to 10 columns, between columns 3 and 4 (215 mm), and
- b) For radiators with more than 10 columns, between columns 4 and 5 (295 mm).

* An inhibitor capsule unique to Alurad is fitted to all radiators during manufacture in order to provide protection against all kinds of corrosion. If the system as a whole is desired to be protected against freezing as well as various kinds of corrosion, the use of ANTICOR 121 is recommended. **Feniş Teknik** may not be held liable for any problems that might arise from the use of another corrosion inhibitor or antifreeze.