

# Kemer

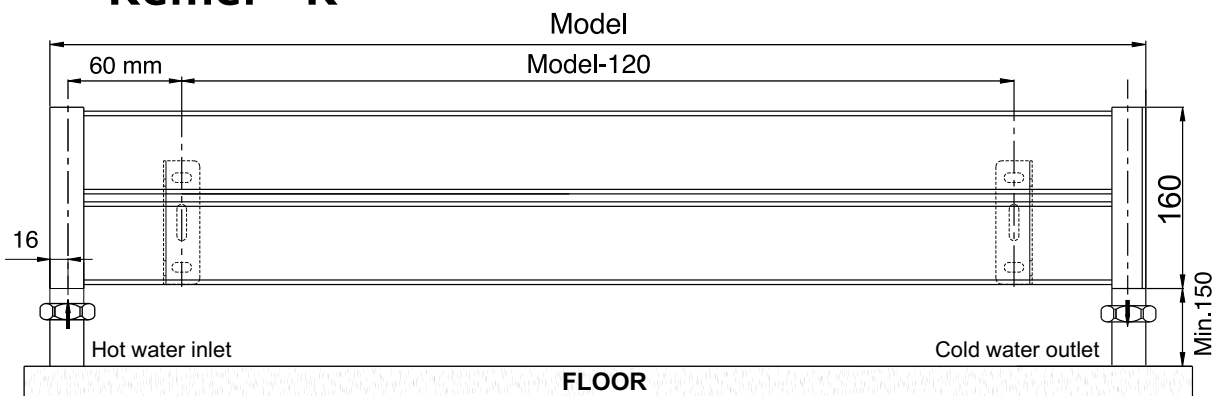

## DIRECTIONS FOR MOUNTING AND USE Kemer - K



Kemer K - Front view

Figure 1

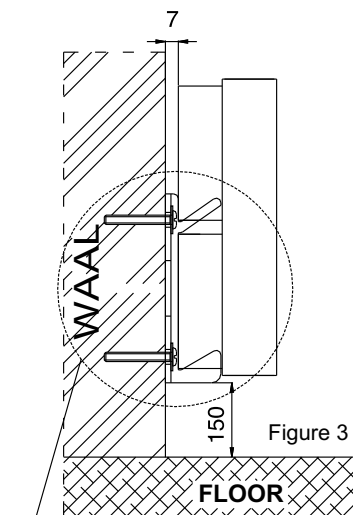

Kemer K - Side view

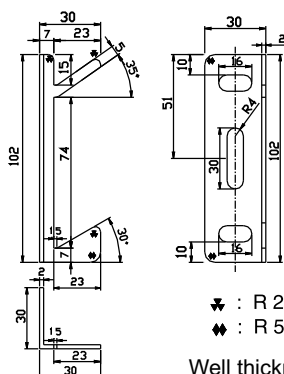

✦ : R 2,5 mm  
✦ : R 5 mm

Well thickness 2 mm

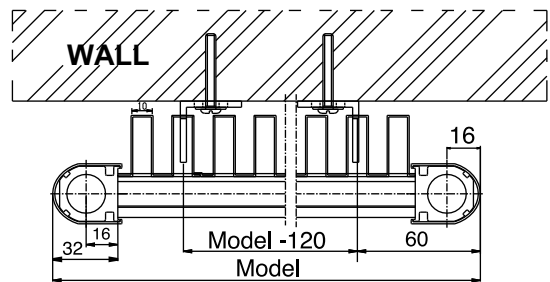

Kemer K - Top view

Figure 2

- 1** After leaving a distance of min. 150 mm from the bottom, the center measurements shall be marked and the hanger elements shall be screwed. The radiator shall be mounted as shown in Figure 3.
- 2** For models larger than 150mm, an additional mounting element shall be fixed to the middle section.
- 3** In the case of 3 K models, the hangers are fixed to the middle column. They are mounted as to be 230 mm above the floor.

